

The Flight Control System of the Hovereye® VTOL UAV

Paolo Binetti¹ and Daniel Trouchet²

Bertin Technologies, UAV Systems
Parc d'activités du Pas du Lac
10bis, avenue Ampère
78180 Montigny-le-Bretonneux, BP 284, France

binetti@bertin.fr, trouchet@bertin.fr

Lorenzo Pollini³ and Mario Innocenti⁴

University of Pisa
Dept. of Electrical Systems and Automation
Via Diotallevi, 2
56100 Pisa, Italy

lpollini@dsea.unipi.it, minnoce@dsea.unipi.it

Tarek Hamel⁵

I3S UNSA-CNRS, UMR 6070
2000 rte des Lucioles -Les Algorithmes-
Bât. Euclide B, B.P. 121
06903 Sophia Antipolis, France

thamel@i3s.unice.fr

Florent Le Bras⁶

Délégation Générale pour l'Armement (DGA)
Laboratoire de Recherches Balistiques et
Aérodynamiques (LRBA)
27200 Vernon, France

florent.le-bras@polytechnique.org

ABSTRACT

This overview paper covers the flight control system of Bertin Technologies' Hovereye® mini vertical takeoff and landing (VTOL) UAV, including development, verification in simulation and flight test results. Hovereye® is a demonstrator of a short range reconnaissance platform in support of army units engaged in urban combat, such as in peace-keeping missions, with an electro-optic day or night camera payload.. This system stabilizes the vehicle, provides operators with easy manual flight commands, and automatically performs mission segments such as automatic landing, in the face of strong gusting wind. The highlights of this paper are: the breadth of its scope, covering a full UAV flight control system, with a special emphasis on control laws; the proposed rapid prototyping solutions have been proven in flight; some experimental results are given; insight is provided into the stabilisation of the unconventional ducted-fan VTOL configuration, which is open-loop unstable and features highly nonlinear dynamics; issues on semi-automatic and autonomous flight are dealt with, including visual-based servo control;. Short films of test flights will complete the presentation.

¹ Flight Control System Manager

² UAV Systems Manager

³ Researcher

⁴ Professor

⁵ Professor

⁶ Guidance & Control Engineer

The Flight Control System of the Hovereye® VTOL UAV

1.0 INTRODUCTION

This overview paper is about the flight control system of Bertin Technologies' Hovereye® mini VTOL unmanned aerial vehicle (UAV). This system stabilizes the vehicle, provides operators with easy manual flight commands, and automatically performs mission segments such as automatic landing, in the face of strong gusting wind. Its design is particularly challenging.

1.1 Motivation and state of the art

A thorough documented practical approach for the design of the GN&C system for such vehicles does not exist, although interesting papers are available [17]. In addition the dynamics of ducted-fan configurations is poorly known and stabilization and control are not yet fully tackled:

- Flight in gusting wind is a major challenge [2], [20]
- Aggressive maneuvering has not been mastered (it has for helicopters at MIT [30])
- Envelope protection for carefree flying has never been treated

In literature: plain linear approaches are fine, but only good for a limited envelope [15], [16]; nonlinear approaches are either too complex [18], or too dependent on knowledge of system dynamics [21], or fail to provide quantitative indications of performance, stability and robustness.

1.2 Scope and highlights

The paper covers the flight control system of the Hovereye® UAV, including development, verification in simulation, and flight test. In addition, in the next chapter a quick introduction is given to the Hovereye® system, including a description of the platform and its ground segment, with special emphasis on the flight control system's avionics architecture and sensor suite.

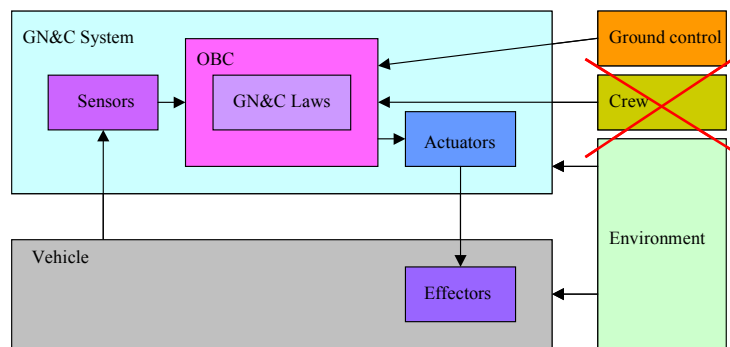

Figure 1: Guidance, Navigation, and Control System (GN&C) of Hovereye and its interfaces

The highlights of this paper are:

- The breadth of its scope, covering a full UAV flight control system
- The proposed rapid prototyping solutions have been proven in flight
- It is about the control of an unconventional VTOL configuration
- Issues on autonomous and semi-autonomous flights are covered
- Experimental results are given

2.0 THE HOVEREYE® VEHICLE

The Hovereye® demonstrator is VTOL UAV, which has been developed to military specifications for very-short range combat intelligence. It is therefore a man-portable platform designed to operate in complex, confined, obstacle-dense environments, with an electro-optic day or night camera payload. Autonomous mini VTOL UAV have been studied and demonstrated, but no operational vehicles exist today, although well funded US programs are helping some demonstrators to reach production, such as within the DARPA Organic air vehicle (OAV) and OAVII programs. There is no equivalent program in Europe with a comparable level of funding.

Bertin designed the Hovereye® on its funds and under a contract from DGA, the French Defence Research and Development Agency, building on its previous know-how gained with the Flying Ball prototype. Hovereye® is a ducted-fan configuration, which is advantageous for many reasons, including compact size and protection from propellers. Its specifications are provided in Table 1. Bertin proved its capabilities with demonstration flights, and will hand out a few prototypes to the French Army test division for field testing.

		<p style="text-align: center;">Specifications</p> <p>Diameter: 50 cm Height: 70 cm Powerplant: Electric Vehicle weight: 4.0 kg Payload: 300 g Endurance: 10 min Range LOS*: 1500 m Range beyond LOS: 500 m Speed: 30 mph Wind speed: 20 mph</p>
--	--	---

Table 1: The Hovereye® System and its specifications

Key advantages of Hovereye® over other platforms are:

- Safety for its operators, thanks to the duct that covers potentially dangerous propeller blades: protected propellers are a must for any vehicle which will function in close proximity of personnel. In addition to safety, shrouding the fans increases the survivability of the vehicle in the event of light shocks against obstacles.
- Low vibration level, thanks to electric propulsion. Hovereye® is one of the few UAVs with electric propulsion and the only VTOL one: one of the strong motivations for this choice is in fact the desire to minimize the effects of mechanical environment on vision payloads.
- High payload/size ratio, allowing to fly high quality sensors in very constrained environments, including indoors.
- Proprietary, user-configurable ground-station, on which new devices and software can be readily integrated, as would it be the case for haptic joysticks or custom man-machine-interfaces for real-time data analysis and post processing.

* Line Of Sight

The Flight Control System of the Hovereye® VTOL UAV

However, there are a number of design challenges to achieve such a vehicle, such as aerodynamics and propulsion, weight and volume reduction, and flight control complexity.

2.1 Shape and aerodynamics

When considering aerodynamics, and in particular controllability, extensive wind tunnel testing and dedicated computational fluid dynamics (CFD) using Bertin's proprietary code CPS (with applications that include Ariane liquid propulsion) have shown a high sensitivity with respect to shape and size on key elements. CFD was essential for converging to a satisfactory shape, much in the same way that Honeywell dealt with the same problem [20] for a similar vehicle, whereas wind tunnel testing was the main tool to establish the aerodynamic database for Hovereye®'s simulator and craft its stability and control laws.

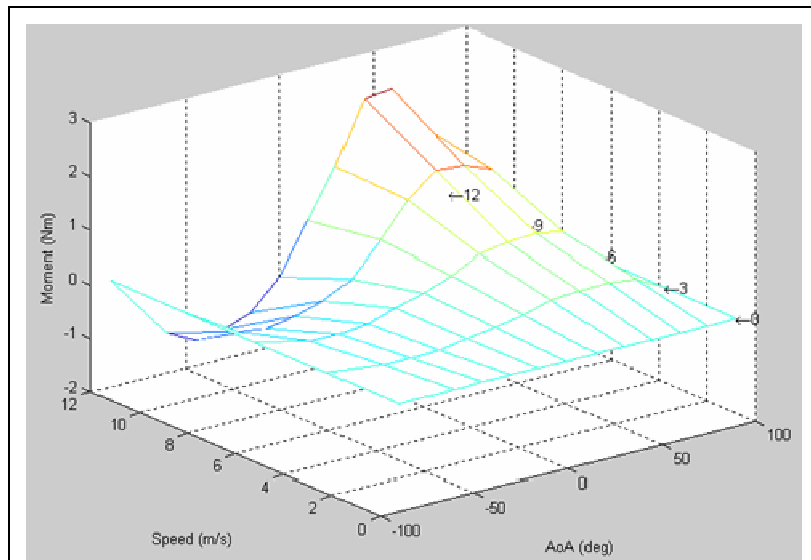

Figure 2: Wind tunnel data

2.2 Avionics

The specifics of an autonomous VTOL mini-UAV drive its avionics' requirements:

- Potentially complex stabilization algorithms and a high-level of autonomy necessitates high computing power and the need for customized solutions
- Weight and cost constraints mean low-performance COTS[†] sensors and limit the level of redundancy
- Exotic functions such as relative navigation, obstacle avoidance and terrain following require a wide array of sensors
- Volume constraints imply tight packaging and potentially harsh EM environment

One of the first subsystems that were studied is the onboard computer. Because of the need for high computing power and a large number of interfaces (ranging from analogue to serial to PWM) to receive sensors' information and to drive actuators, an in-house development was opted for. Our computer is based on three DSP of the TI2812 family and a CAN Bus, and has been developed exploiting synergy with Bertin's electronics and optronics branch in Aix-en-Provence.

[†] Commercial Off The Shelf

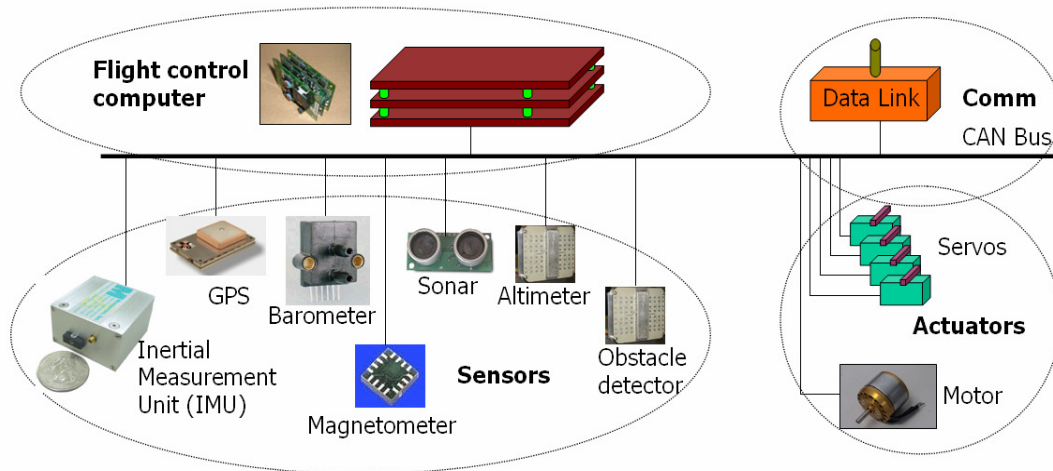

Figure 3: Hovereye avionics architecture

2.3 Sensors

Concerning sensors, in recent years the UAV industry has witnessed a number of legacy suppliers and of new entrants rushing to develop and market ever more integrated units. Gone are the days when small systems integrators (especially naïve newcomers or cash-stripped university labs) had to craft their inertial measurement units from gyros and accelerometers. Still, no miracle sensor suite is yet available offering a fitting solution at an affordable price and low weight.

The advantage of sensor suites is that they offer a qualified and self-contained package, and possibly even a ready-to-use attitude and navigation solution, thereby virtually transferring development costs and risks associated with sensors choice, integration, calibration, and hybridation, from the system integrator to the supplier. The disadvantages are that these units are often black boxes, whose functioning is not completely mastered and cannot be adapted to specific applications without extra charges from the supplier. Recurrent cost may also be a consideration, especially for the extreme case of expendable UAVs.

So the key decision in sensor procurement for a mini UAV platform manufacturer is the level of integration from which to start off. This decision is especially critical for compact VTOL vehicles, whereas relatively roomy, conventional fixed wing aircraft will generally support a COTS system of the type that Athena Technologies or WEpilot offer, which also include some computing power. A number of manufacturers have started units such as the Microbotics MIDG II, which is a GPS/INS/Magnetometer “package for use in applications requiring a full state vector including attitude, position, velocity, acceleration, and angular rates”. Heterogeneous sensor data are fused in the unit’s processor in order to generate the state vector.

Bertin Technologies opted for a lower level of integration, choosing a commercial MEMS IMU as the core of its sensor array. In addition, a set of complementary COTS sensors including a GPS receiver, a barometer, as well as magnetometers have been chosen to be integrated onto the system and help provide a sustainable navigation solution. The exception to the COTS rule has been the relative altimetry sensor: measurement range, sensor weight, and form factor led Bertin into ultra wide band (UWB) radar technology. A specific development was contracted to a small company with an extensive background in UWB devices and brought to fruition within few months.

The Flight Control System of the Hovereye® VTOL UAV

3.0 FCS ARCHITECTURE AND DEVELOPMENT

This chapter is a summary of the main issues from a system standpoint. It includes a description of how the control laws are structured, and of the rationale behind the chosen architecture. Also insight is provided into the special development logic that addresses the need to quickly get an UAV prototype to flight and autonomy by exploiting modern technologies.

3.1 Control laws architecture

A functional point of view is the key to the understanding of the system. In order to reduce development risk, a “vertical” decomposition is made, resulting in a hierarchical structure where higher layers are built on lower feedback loops. The type and heterogeneity of sensors contribute to the choice of decoupling the system into parallel channels, a “horizontal” decomposition, which contributes to the modularity of the system, a requirement established to ensure growth potential.

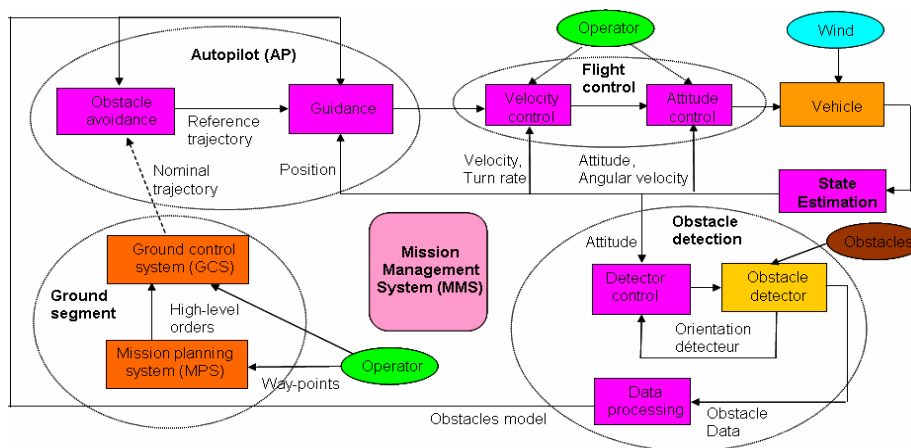

Figure 4: Control laws functional architecture

Among the critical choices to make when crafting a flight control architecture is what dynamic variables to control with what actuators [4], including both external variables and internal ones, and this is particularly true for a vehicle with an unconventional configuration, designed for a little known mission. For example we determined that attitude was a useful intermediate control variable to be accessed by higher level modules in touch with the test pilot/operator, whereas “generalized” velocity tracking was ideal for manual operator control. To do this, we used four major criteria:

- The need to provide the operator with a very intuitive, low workload manner to control the vehicle safely and effectively
- The ease to perform envelope protection, having in mind almost totally carefree operation both in auto and manual flight, including protection from controlled flight into terrain
- The availability of measurements or estimations for feedback-controlled variables
- The anticipated simplicity of the resulting control law modules: choosing the right architecture can go a long way into rapidly coming up with successful control laws

3.2 Development logic

A classical FCS development logic [3],[5] has been modified to take into account characteristics of a small research and development prototype for which testing is relatively easier than obtaining very accurate models for high-fidelity simulation, resources are limited, and schedule constraints are severe [7]. Another major factor has been the availability of new technologies [8] such as model-based design and automatic real-time code generation, for example those provided by the Mathworks.

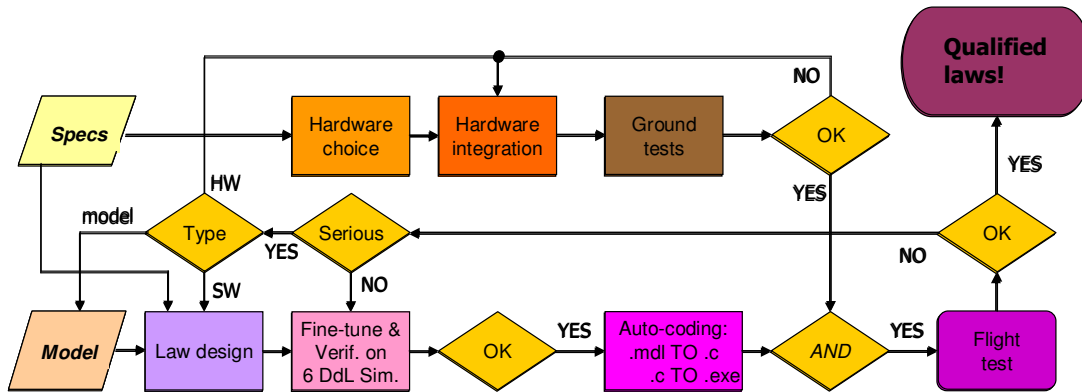

Figure 5: FCS development logic

Given the limited experience of the project team in designing and flight testing an UAV demonstrator, in order to lower the development risk, it was decided to opt for an incremental approach, testing each functional module as soon as it was ready and validated in medium-fidelity simulation. First flight happened much sooner than after system design completion and validation: the stabilisation function was enough. So the relative simplicity of the more traditional “design all, validate all, and qualify all” was traded for a lower risk approach that matched the difficulty of the task at hand with the learning curve of the team, and helped to spot unexpected problems as soon as possible. In fact, this incremental, modular approach has also been followed by other demonstrator programs.

The difficulty to come up with pertinent specifications for a VTOL vehicle capable of helicopter-like and aircraft-like flight and of the transitions between the two modes has been found in X-35B program, which was the Joint Strike Fighter (JSF) concept demonstration program [6]. For such vehicles, as well as for more conventional control-configured manned or unmanned machines, drawing specifications straight out of military standards, such as MIL-STD-1797A (aircraft) and MIL-F-83300 (rotorcraft) does not systematically ensure good flying qualities. We addressed this issue crafting our specifications from operational needs, in a way which is similar to the solution found within the X-35B program and the F-22 program.

In order to make the most of the model-based approach, a medium-fidelity 6 degrees of freedom simulator has been developed [1], including nonlinear flight dynamics, thanks to extensive wind tunnel study, sensors error models and actuator nonlinear dynamics, thanks to ground testing of components and flight tests. The safety pilot and the ground control operator interfaces are also modelled, in such a way that full scenarios can be played, that include a flight program of operator actions, wind gusts, and equipment failures.

The Flight Control System of the Hovereye® VTOL UAV

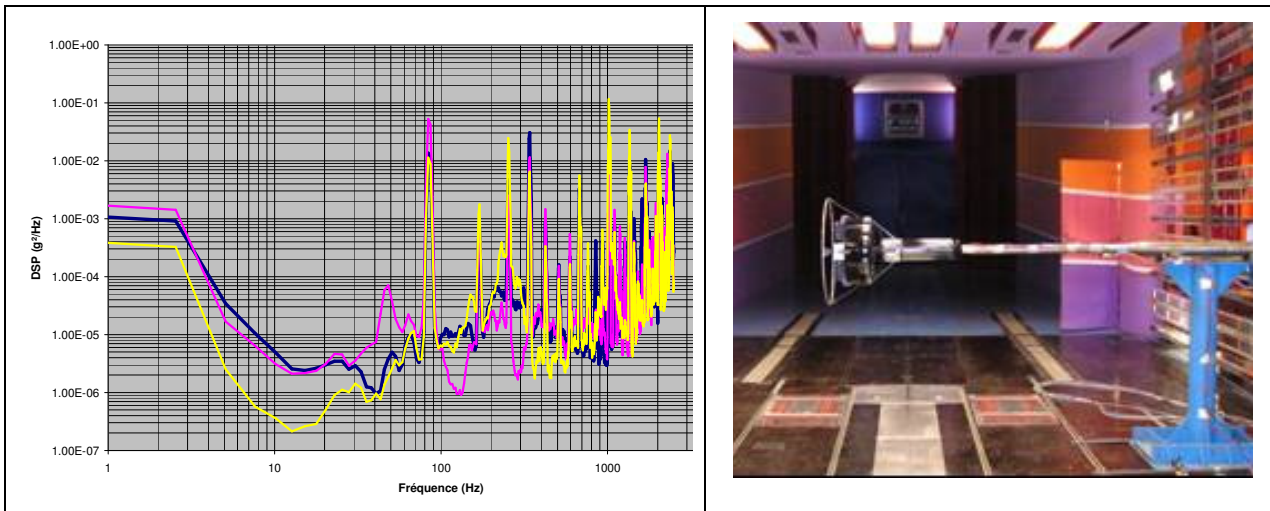

Figure 6: Results of vibration test (left) and wind tunnel testing at Saint Cyr (right)

3.3 Automatic real-time code generation

Automatic real-time code generation has been in vogue for a while, with most companies having used it to some degree, with in-house tools. The payoff of this technology is well known: “Airbus has been able to reduce coding error by 88% or greater through the use of automatic code generation on the A320 and A340 programs. Automatic code generation accounted for 70% of the Airbus A340 code” [8]. The novelty of recent years has been the arrival on the market of commercial tools, like the Mathworks’ product line, that have increasingly gained a reputation among aerospace professionals, up to the point of being actually used for mission-critical applications. Although a certain resistance still exists (and problems have been encountered, for example in the efficiency of generated code), both the tools developers and system integrators are paving the way to the application of this technology to flight-critical applications in human-rated systems. Onboard of Bertin’s Hovereye® all the executable real-time code for stability and control has been automatically generated from GN&C laws specifications and has always performed flawlessly.

4.0 STABILITY AND CONTROL AUGMENTATION

A stable and manoeuvrable vehicle is the foundation on which all higher-level functions, such as guidance are built: without it, they are useless. Moreover, this unconventional configuration also needs a proper pilot interface, in order to be test-flown by a model helicopter pilot.

4.1 Hovereye®'s control challenges

Hovereye®'s is a particularly challenging plant to stabilize and control, for a number of reasons:

- It is an unstable machine, whose dynamics can be particularly rapid (see the figure below): it cannot be flown without a properly sized artificial stabilization system [12];
- Aerodynamic moments are significant and very sensitive to flight conditions, their dependence from relative wind being nonlinear and complex to model;
- Relative wind is hard to measure or estimate
- Control surface effectiveness depends on flight conditions in addition to thrust; this can also produce undesirable control couplings
- Hovereye routinely performs big rotations and flies at high pitch and roll: this implies nonlinear kinematic coupling
- Because of aggressive 3D manoeuvring, nonlinear inertial coupling cannot be neglected

In the figure below, an excerpt of the traces of an actual early development flight test where something went wrong – not long enough to crash the vehicle, luckily – gives an idea of the level of instability in a *mild* flight condition. At about 647.5 s flight test operators accidentally shut down part of the stability and control augmentation system (SCAS), so that the pitch axis went open-loop and out of control; fortunately the pitch controller was reactivated just *one* second after, and reacted with full control surface deflection orders, recovering the vehicle with the pitch error peaking at 10 degrees.

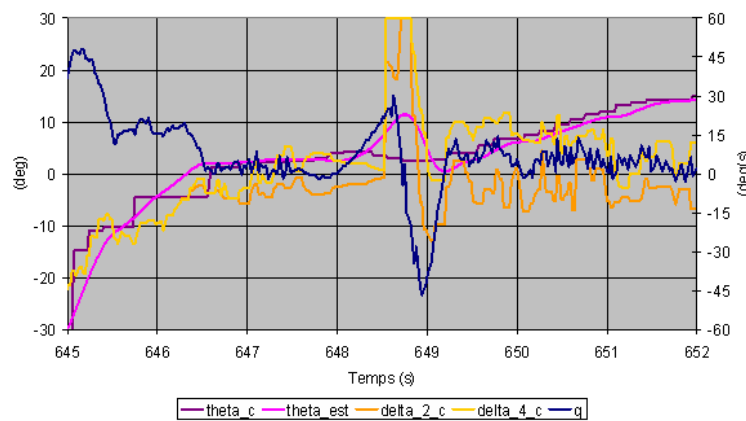

Figure 7: A flight test incident shows ducted-fan instability in action

We tackled this complex problem with the following design rules:

- *Divide et impera*: reduction into simple problems has been sought ; dynamic parts of the controllers shall be single-input single-output (SISO), whereas multiple-input multiple-output (MIMO) is allowed for static parts

The Flight Control System of the Hovereye® VTOL UAV

- Each part of the controller must have a clear physical interpretation
- Reliance on internal modelling and non-inertial measurement must be minimal

The result is the following architecture of the SCAS, which bears resemblance to some architectures proposed for the control of re-entry vehicles [13]:

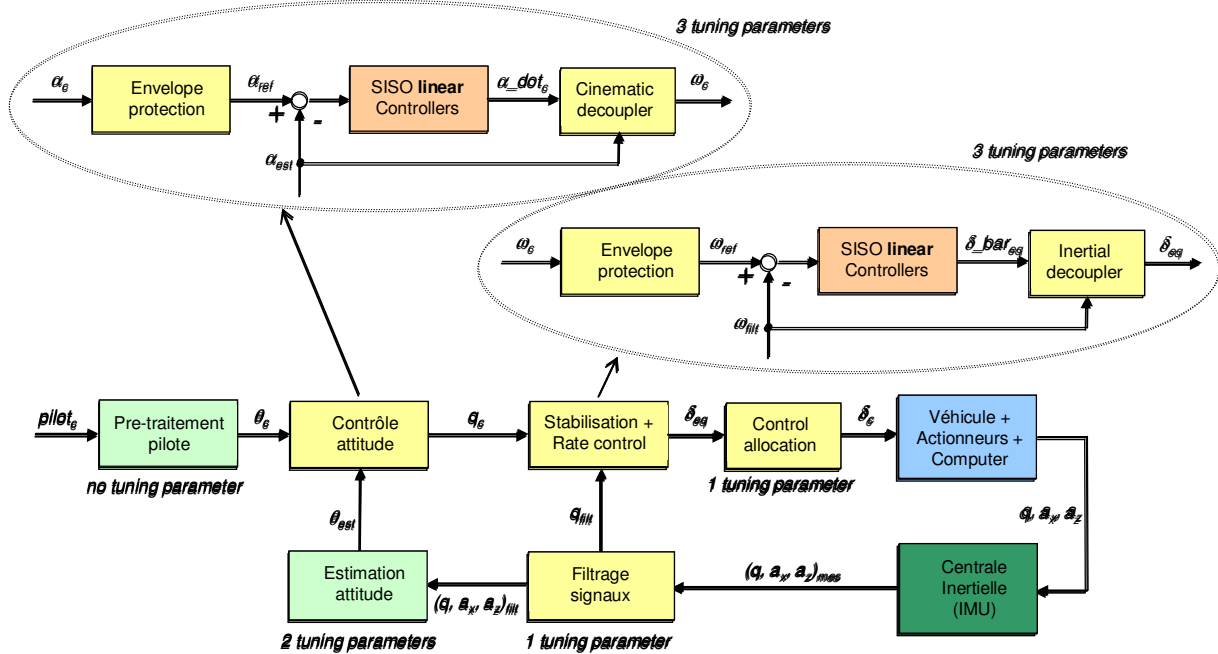

Figure 8: Hovereye®'s SCAS architecture

4.2 Control allocation

Allocation algorithms are the bridge from the control system's 3 moments "wants" to its resources, the 4 thrust vectoring effectors. Hovereye®, since its first flights has employed the simplest approach, which has proven consistently highly effective. However, the desire to expand the envelope of the vehicle has prompted a more detailed analysis, which has resulted into a more efficient strategy, whose key idea is to give high priority to demands concerning the most critical axis, while guaranteeing minimal control for the others. This strategy indirectly addresses part of the aerodynamic coupling problems mentioned above.

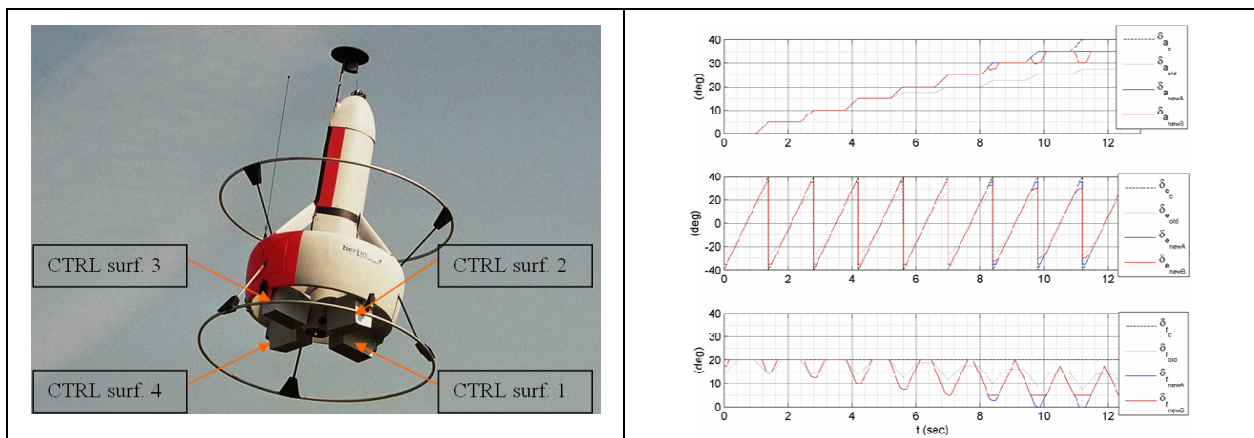

Figure 9: Hovereye®'s control surfaces and allocation strategy trade-off analysis curves

4.3 Stabilisation and angular rate control

One of the key attractive of linear controllers is their generalized performance indicators (GPIs) and their sometimes simple relationship with tuning parameters: performance (we use 4 per channel & function), stability (we use 3 per channel & function); robustness (we use 4 per channel & function); control moderation (we use 2 per channel / function). Some, such as low frequency gain margin (unstable systems) and delay margin, are less familiar, but extremely useful and applicable to nonlinear analysis.

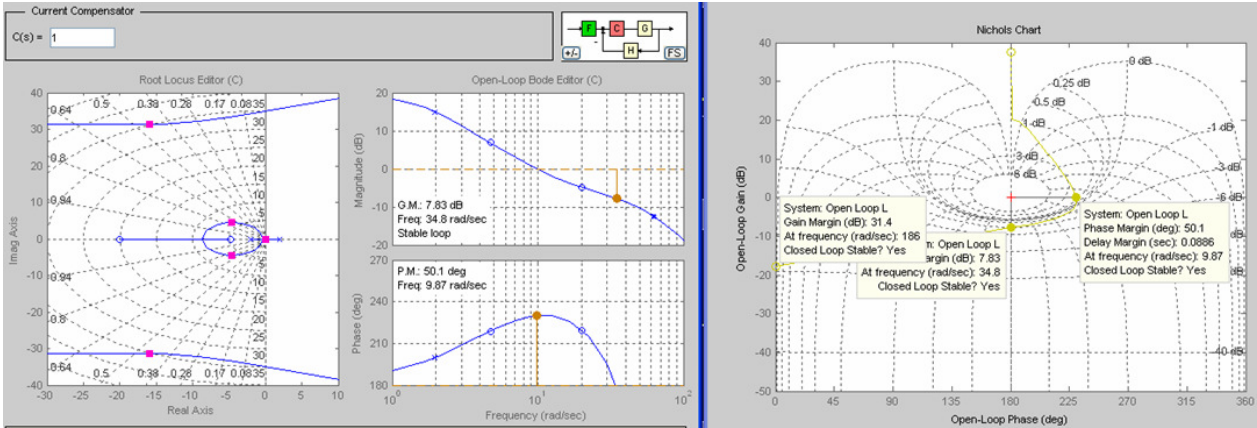

Figure 10: Stabilisation and angular rate control laws design iteration

Simulation results are excellent and are confirmed by flight test. The figures below concern pitch dynamics: θ is the pitch angle, δ are control surface deflection and q is the pitch rate; the subscript c indicates a command.

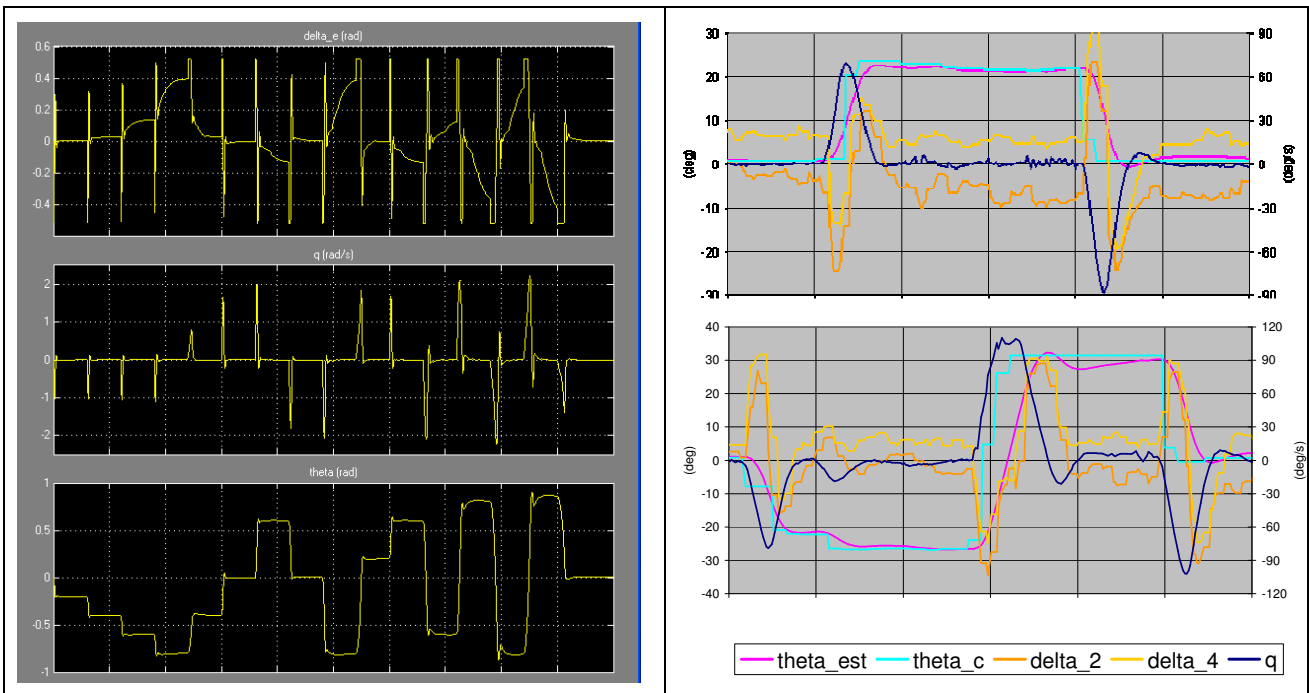

Figure 11: Simulation and flight test results

5.0 NAVIGATION, GUIDANCE, AND HIGH LEVEL FUNCTIONS

5.1 State estimation

Unlike most known approaches, both in academia and in industry [23],[24], Bertin's approach to state estimation is *not* an extended Kalman filter crunching most of on-board sensor outputs in order to observe a rather large set of states. The architecture used on the Hovereye® is a collection of dedicated estimators which each address a subset of the full state by fusing the most appropriate sensors with variants of the complementary filtering technique. The advantage of this method is once again to separate variables in order to solve a complex problem, but also to introduce some level of partitioning in order to add robustness to sensor failure, and a limited number of tuning parameters.

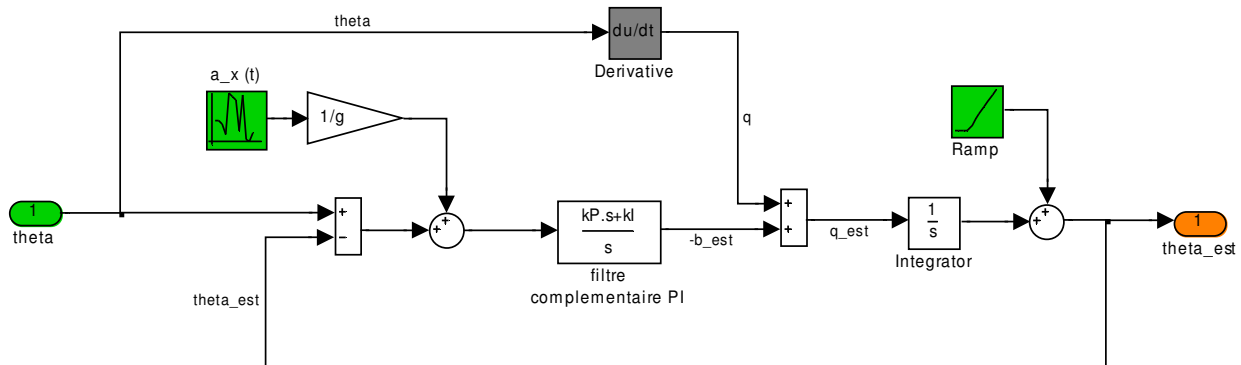

Figure 12: A simplified one-channel complementary filter for pitch angle estimation

Thus, three nonlinear complementary filters of different orders run in parallel on the onboard computer, the first one for attitude estimation [25], the second one for vertical states estimation – including vertical speed, relative and absolute altitude – and the third one for horizontal velocity and position estimation. All can fail in the latter two without compromising the integrity of the attitude solution, which is flight critical. This is particularly useful considering the low quality sensors and the low redundancy level available in current and near-future micro UAVs.

5.2 Visual servoing

A VTOL mini UAV like Hovereye® is highly representative of the types of vehicles that could benefit from the development of vision aided flight control technologies. Indeed, the weight and cost of the machine is such that no self-contained navigation, such as heavy and expensive, high-precision, inertial measurement units can be installed. And the contexts in which Hovereye® is designed to operate, such as urban warfare, are such that GPS signal integrity will never be guaranteed (jamming and poor satellite signals), thus precluding a reliable correction of inaccurate inertial navigation. Besides, navigation and control based on absolute positioning would certainly prove inadequate for a vehicle for which survival depends on its relative position with respect to unknown objects, and whose utility resides in capturing visual information on objects whose absolute position cannot be identified a priori. Making the most of context-dependent cues through an information-rich source as on-board visual sensors is thus vital to the success of the missions of vehicles like Hovereye®.

The most promising technique to do this is sensor-based control, especially thanks to its low computational requirements, with respect to other methodologies which could not possibly be implemented in a feedback control loop for high bandwidth flying machines such as small UAVs. In partnership with University of Nice's I3S lab and Australian National University, Bertin modified, integrated and flight tested a novel visual servoing algorithm [28], with the objective to demonstrate positioning task with respect to a target using feedback from a vehicle-fixed camera and a commercial-grade IMU.



Figure 13: Hovereye demonstrating position-hold with vision

This result, documented in [29] with theoretical foundations as well as flight test results, is the first successful flight demonstration of relative-position-hold with visual servoing, to the authors' knowledge. This concrete proof of the adaptation of Hovereye® to the task and the powerful collaboration between Bertin and the I3S lab proved important in obtaining significant funding from the French Research Agency (ANR) for a research and technology program called SCUAV, Sensory Control of Unmanned Aerial Vehicles, in partnership with a number of other labs, including the French Centre for Atomic Energy (CEA), the University of Compiègne, the French Institute for Research in Control (INRIA), and the IRISA lab of CNRS. This program holds the promise of more ground-breaking results.

6.0 BIBLIOGRAPHY

6.1 Modelling and Simulation

- [1] M. V. Cook, "Flight Dynamics Principles", 1st Ed., Arnold, London, UK, 1997
- [2] M. M. Lazareff, "L'Hélice Carénée – Performances actuelles et possibilités futures", Colloque d'aérodynamique appliquée, Ecole National Supérieure de l'Aéronautique – Paris, November 1964

6.2 Control system architecture and development

- [3] R. W. Pratt, "Flight Control Systems – Practical Issues in Design and Implementation", IEE & AIAA, 2000
- [4] M. B. Tischler (ed.), "Advances in Aircraft Flight Control", Taylor & Francis, London, 1996
- [5] P. A. Vidal, "NH-90 Helicopter Fly-By-Wire Flight Control System", 53rd American Helicopter Society Annual Forum, Virginia Beach, VA, April 1997
- [6] G. P. Walker, D. A. Allen, "X-35B STOVL Flight Control Law Design and Flying Qualities", AIAA 2002-6018, 2002 Biennial International Powered Lift Conference and Exhibit, 5-7 November 2002, Williamsburg, Virginia
- [7] J. D. Colbourne, M. B. Tischler, K Rodgers, "Flight Control Design for an Unmanned Rotorcraft Program with a Rapid Development Schedule", 57th American Helicopter Society Annual Forum, Washington DC, May 2001
- [8] Jose K. Menendez, "Building Software Factories in the Aerospace Industry", M.S. Thesis, Massachusetts Institute of Technology, February 1997

6.3 Stability and control

- [9] P. Bolzern, R. Scattolini, N. Schiavoni, "Fondamenti di Controlli Automatici", McGraw-Hill
- [10] NATO RTO, "Flight Control Design – Best Practices", RTO-TR-029, December 2003
- [11] J. A. Franklin, "Dynamics, Control, and Flying Qualities of V/STOL Aircraft", 1st Ed., AIAA Education Series, Reston, VA, 2002
- [12] G. Stein, "Respect the Unstable", IEEE Control Systems Magazine, pages 12-25, Aug. 2003
- [13] D. Ito, J. Georgie, J. Valasek, and D. T. Ward, "Reentry Vehicle Flight Controls Design Guidelines: Dynamic Inversion", NASA/TP-2002-210771, March 2002
- [14] Pollini, L., Innocenti, M., Greco, L., "Stability Issues in Dual time Scale Systems", Automatica, num. 2, vol. 39, p. 273, 2003

6.4 Stabilization and control of ducted fans

- [15] S. Ando, "A simple Theory on Hovering Stability of One-Ducted-Fan VTOL", Trans. Japan Soc. Aero. Space Sci., Vol. 29, No. 86, pages 242-250, Feb. 1987.

- [16] J. E. White, J. R. Phelan, “Stability Augmentation for a Free Flying Ducted Fan”, AIAA 87-2453
- [17] L. Lipera, J. D. Colbourne, M. Tischler, M. Hossein Mansur, M. C. Rotkowitz, and P. Patangui, “The Micro Craft iSTAR Micro Air Vehicle: Control System Design and Testing”, 57th American Helicopter Society Annual Forum, Washington DC, May 2001
- [18] R. Franz, M. Milam, and J. Hauser, “Applied Receding Control of the Caltech Ducted Fan”, Proceedings of the American Control Conference, Anchorage, USA, May 2002, pp. 3735–3740.
- [19] G. Avanzini, S. D’Angelo, and G. de Matteis, “Performance and Stability of Ducted-Fan Uninhabited Aerial Vehicle Model”, Journal of Aircraft, Vol. 40, No. 1, 86-93, Jan.-Feb. 2003.
- [20] J. Fleming, T. Jones, P. Gelhausen, and D. Enns, “Improving Control System Effectiveness for Ducted Fan VTOL UAVs Operating in Crosswinds”, 2nd “Unmanned Unlimited” Systems, Technologies, and Operations, San Diego, California, AIAA-2003-6514, September 2003. .
- [21] C. M. Spaulding, M. H. Mansur, M. B. Tischler, R. A. Hess, and J. A. Franklin, “Nonlinear inversion Control for a Ducted Fan UAV”, AIAA 2005-6231
- [22] J. M. Pflimlin, T. Hamel, P. Soueres, and R. Mahony, “A Hierarchical Control Strategy for the Autonomous Navigation of a Ducted Fan UAV”, IEEE International Conference on Robotics and Automation (ICRA’06)

6.5 State estimation

- [23] RTO Educational Notes, “Advances in Navigation Sensors and Integration Technology”, EN-SET-064, February 2004
- [24] D. Titterton et J. Weston, “Strapdown Inertial Navigation Technology”, 2nd Edition, Institute of Electrical Engineers and the American Institute of Aeronautics and Astronautics, 2004
- [25] J. M. Pflimlin, T. Hamel, P. Soueres, N. Metni, “Nonlinear attitude and gyroscope’s bias estimation for a VTOL UAV”, 16th IFAC World Congress, Prague, Czech republic, 2005

6.6 Guidance

- [26] M. Innocenti, L. Pollini, “Sistemi di Guida e Navigazione”, Appunti delle lezioni A.A. 2003-2004, Pisa, January 2004
- [27] M. Krstic, P.V. Kokotovic and I. Kanellakopoulos, “Nonlinear and adaptive control design”, John Wiley & Sons, Inc. New York, 1995
- [28] T. Hamel, R. Mahony, “Visual servoing of an under-actuated dynamic rigid-body system: An image based approach”, IEEE Transactions on Robotics and Automation, pages 187-198, April 2002
- [29] F. Le Bras, R. Mahony, T. Hamel and P. Binetti, “Adaptive filtering and image based visual servo control of a ducted fan flying robot”, IEEE Conference on Decision and Control, CDC06, San Diego, USA, December 2006
- [30] E. Frazzoli, M.A. Dahleh, and E. Feron, “A Hybrid Control Architecture for Aggressive Maneuvering of Autonomous Helicopters”, 1999 IEEE Conference on Decision and Control

The Flight Control System of the Hovereye® VTOL UAV

